

OWNER'S MANUAL

THE BATTERY THAT GOES TO EXTREMES



EnerSys
Power/Full Solutions

ODYSSEY[®]
THE EXTREME BATTERY

INTRODUCTION

The ODYSSEY® battery ingeniously uses absorbed glass mat (AGM) technology to offer, in one box, the characteristics of two separate batteries. It can deep cycle as well as provide enormous cranking power - it is almost as if a champion long distance runner and a world class sprinter are one and the same person.

These batteries are capable of providing engine cranking pulses in excess of 2250A for 5 seconds as well as 400 charge/discharge cycles to 80% depth of discharge (DOD). A typical starting, lighting and ignition (SLI) battery can do one or the other, but not both. It is either a sprinter or a long distance runner; ODYSSEY batteries will do both — provide short duration high amperage pulse or low rate long duration drains.

In order to achieve the full design cycle life of ODYSSEY batteries in cyclic applications the charge current must be a **minimum of 40% of the battery's 10-hour rating (column 8 of the chart on page 5)**. Thus the minimum charge current for a PC925 battery in a cycling application is 10.8 amps (40% of 27Ah). Please refer to Figure 6 of the ODYSSEY application manual for a detailed discussion of the recommended charge profile for ODYSSEY batteries in cycling applications. The manual may be downloaded from www.odysseybattery.com.

WHY USE ODYSSEY® BATTERIES?

GUARANTEED LONGER SERVICE LIFE

With an eight to twelve year design life (float) and a three to ten year service life, ODYSSEY batteries save you time and money because you do not have to replace the battery as often. ODYSSEY batteries are warranted against factory defects for two (2) years for powersports applications; three (3) years in automotive, marine, commercial and industrial applications and; four (4) years in the case of the 75/86-PC1230, 25-PC1400, 35-PC1400, 34-PC1500, 34/78-PC1500, 65-PC1750, 31-PC2150 and PC2250 batteries, except Trolling Thunder™/Marine Dual Purpose labeled batteries, for which the applicable Warranty Period is three (3) years. Since actual warranty can vary with your geographical location, please check with your ODYSSEY battery representative for the warranty specific to your application.

SUPERIOR CRANKING AND FAST CHARGE CAPABILITY

The 5 second cranking power of ODYSSEY batteries is double to triple that of equally sized conventional batteries, even when the temperature is as low as -40°C (-40°F), -30°C (-22°F) for PC2250. Also, with simple constant voltage charging (alternator or independent charger), there is no limitation on the inrush current, so the user is assured of fast charge recovery.

MOUNTING FLEXIBILITY

The ODYSSEY battery may be installed in any orientation (except inverted) without sacrificing any performance attributes. There is no fear of any acid spillage as ODYSSEY batteries recycle the internal gas during operation or charging. The valve regulated design of the ODYSSEY battery eliminates the need for an acid vent tube; eliminating the fear of acid burns or damage to expensive chrome or paint.

SUPERIOR VIBRATION RESISTANCE

ODYSSEY batteries are of military grade technology and have endured rigorous tests that demonstrate their overall ruggedness and exceptional tolerance of mechanical abuse.

READY OUT OF THE BOX

ODYSSEY batteries are shipped fully charged. If the ODYSSEY battery's voltage is 12.65V or greater, simply install the battery in your vehicle and you are ready to go! If below 12.65V, boost charge following the instructions in the ODYSSEY battery Owner's Manual and/or Technical Manual. Putting a boost on the battery will not damage it, even if its voltage reads higher than 12.65V.

WORRY-FREE SHIPPING

Owing to the drycell design, the US Department of Transportation (USDOT) has classified the ODYSSEY battery as a nonspillable, so it may be shipped worry-free by express service or by air.

LONGER STORAGE LIFE

Unlike conventional batteries that require a recharge every six to twelve weeks, the ODYSSEY battery can be stored for up to two years at 25°C (77°F) from a fully charged state. These batteries can be stored for two years or when the open circuit voltage (OCV) drops to 12.00V, whichever comes first.

DEEP DISCHARGE RECOVERY

Should the ODYSSEY battery become deeply discharged, simply recharge following instructions in this manual.

INSTALLATION

Your ODYSSEY® battery is normally ready to install right out of the box! Measure the battery voltage; if it is 12.65 volts or greater, install; if less, then refer to the charging section.

ANY OF THE FOLLOWING WILL VOID YOUR WARRANTY:

- EXPOSING NON-BCI GROUP SIZE BATTERY TO GASOLINE OR DIESEL FUEL
- REMOVING THE LABELED COVER
- REMOVING OR DESTROYING THE BATTERY'S DATE CODE

DO NOT SHORT CIRCUIT YOUR ODYSSEY® BATTERY'S TERMINALS!

Remove any metallic items such as watches, bracelets and other personal jewelry to ensure safe installation.

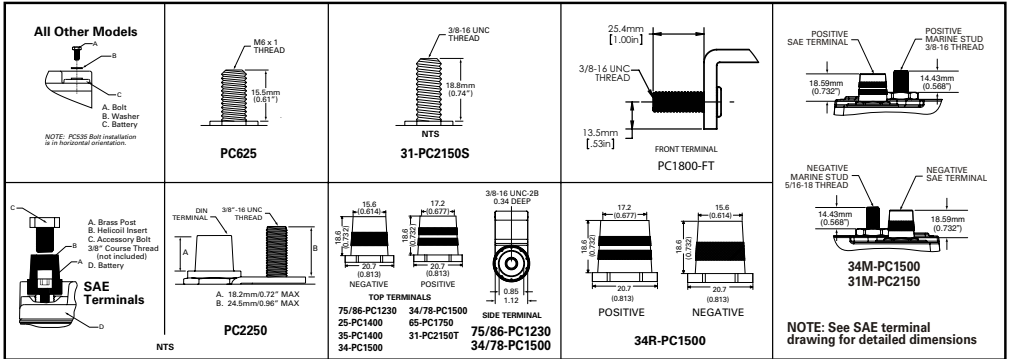

1. Using proper procedures as recommended by the vehicle manufacturer, carefully disconnect the cables from your old battery and remove it from the vehicle. Return the spent battery to the battery dealer for proper recycling.
2. Inspect existing battery cables for corrosion, acid damage or insulation deterioration. Replace if deterioration is present.
3. Position your ODYSSEY battery in the battery holder and fasten firmly to the vehicle.
 - Optional height adapter may be used on both 34-PC1500 models for installations where a group 24 or group 27 is required. Snap the adapter securely into place on the bottom of the battery. In some installations, either 34-PC1500 model with this adapter may be used to replace a group 24F or 27F depending on required cable length.



PC1800-FT Installation:

- Remove existing terminal cover plate from product. Utilizing a 5mm Hex Bit, remove the existing "L-Terminal" brackets from the product.

NOTE: Do not discard the terminal bolts.

- Apply the two new 3/8" threaded "L-terminals" included in the PC1800-FT kit and bolt them in place with the existing terminal hardware.
- Torque bolts to 9.0 Nm (80 in-lbs.).
- Remove adhesive backing from the new terminal cover plate provided in the PC1800-FT kit and apply the cover to the product.

NOTE: Care should be taken not to short circuit the PC1800-FT battery terminals during installation. Insulated caps have been provided for the 3/8" threaded terminals.

NOTE: Do not expose to Petroleum based materials.

4. Connect the positive cable from your ignition to the Positive (+) terminal.
5. Connect the negative cable from your engine or chassis to the Negative (-) terminal.
6. Torque the bolt, screw or nut per the specification noted in table. If you're using the Accessory Bolt (C), hold the Brass Post (A) with vise grips and counter torque. Do the same with General Motors™ automotive battery cable installation.

NOTE: This is a valve regulated sealed battery and never needs to have water or electrolyte (acid) added.

Warranty will be void if opened!

SPECIAL NOTICE!

- CUSTOM V-TWIN MOTORCYCLE INSTALLATIONS USING ODYSSEY PC535, PC545, PC545MJ, PC680MJ & PC925LMJ BATTERIES

If your V-Twin motorcycle is equipped with a standard 32 amp single phase stator/alternator, the appropriate ODYSSEY battery may run out of charge after about 150 miles of riding. To avoid this situation we strongly recommend the ODYSSEY Ultimizer™ charger model OMAX-6A-1B for existing 32 amp equipped bikes, with the charger being operated continuously during the non-use of the bike and/or installing a 3-phase 40 amp or higher stator/alternator, especially in new bikes.

- Prolonged storage of vehicles with fuel injection computers, alarms, GPS and other electrical devices that require continuous battery power to support active memories; this power drain must be offset with a maintenance-float charger, periodic charging or disconnecting the battery to prevent the establishment of irreversible crystallized sulphation in the battery plate oxide. Failure to address this destroys battery capacity and voids the warranty, as this is not a warranted defect in materials or workmanship.

ODYSSEY® BATTERY STORAGE AND DEEP DISCHARGE RECOVERY

Figure 2 shows the relationship between open circuit voltage (OCV) and state of charge (SOC) for the ODYSSEY® battery.

(A) How do I know the state of charge of the battery?

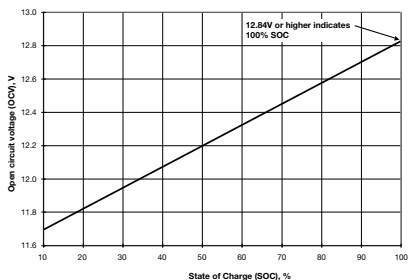

Figure 2: ODYSSEY® Battery OCV vs. SOC

As long as the battery has not been charged or discharged for 6 or more hours, Figure 2 can be used to determine the SOC of the ODYSSEY battery. Use a high quality digital voltmeter to measure its OCV. The graph shows that a healthy, fully charged ODYSSEY battery will have an OCV of 12.84V or higher at 25°C.

(B) How long can the battery be stored?

Refer to Figure 3 below. At 25°C (77°F), these batteries can be stored for up to 2 years. The lower the temperature, the longer the storage time. The battery must be charged before storage.

Roughly every 10°C (18°F) increase in temperature cuts storage time in half. If the temperature rises to 35°C (95°F) the battery may be stored for only 1 year before a recharge becomes necessary. Figure 3 will apply only if the battery is fully charged before storage.

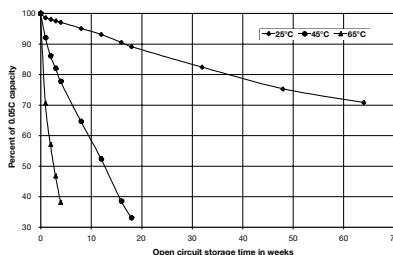

Figure 3: ODYSSEY® Battery storage time at temperatures

MODEL	Voltage	PhiCA** (5 Sec)	CCA*	HCA	MCA	Nominal Capacity		Reserve Capacity Minutes	Length inches (mm)	Width inches (mm)	Height inches (mm)	Weight lbs (kg)	Terminal	Torque Specs in-lbs (Nm-max)	Internal Resistance (mΩ)	Short Circuit Current
						(20 Hr Rate - Ah)	(10 Hr Rate - Ah)									
PC310	12	310	100	200	155	8	7	9	5.43 (138.0)	3.39 (86.0)	3.98 (101.0)	5.9 (2.7)	M4 Receptacle	8.9 (1.0)	27.1	455A
PC535	12	535	200	300	265	14	13	21	6.70 (170.2)	3.90 (99.1)	6.18 (157.0)	12.0 (5.4)	M6 Stud	40 (4.5)	8	1000A
PC545	12	545	185	300	240	13	12	18	7.00 (177.8)	3.38 (85.9)	5.17 (131.3)	12.6 (5.7)	M6 Receptacle	50 (5.6)	10	1200A
PC625	12	625	265	440	350	18	17	27	6.70 (170.2)	3.90 (99.1)	6.89 (175.0)	13.2 (6.0)	M6 Stud	40 (4.5)	7	1800A
PC680	12	680	220	370	300	16	16	24	7.15 (181.5)	3.00 (76.3)	6.65 (167.8)	15.4 (7.0)	M6 Receptacle† or SAE 3/8" Receptacle	50 (5.6)	7	1800A
PC925	12	925	380	625	500	28	27	52	6.64 (168.6)	7.05 (179.0)	5.04 (128.0)	26.0 (11.8)	M6 Receptacle† or SAE 3/8" Receptacle	60 (6.8)	5	2400A
PC1200	12	1200	550	860	725	42	40	78	7.87 (199.9)	6.66 (169.1)	6.80 (172.7)	38.2 (17.4)	M6 Receptacle† or SAE 3/8" Receptacle	60 (6.8)	4.5	2600A
75/86-PC1230	12	1230	730	1050	815	55	50	100	9.46 (240.3)	6.99 (177.5)	7.92 (201.2)	45.5 (20.6)	TOP SAE SIDE 3/8" Receptacle	60 (6.8)	2.5	3100A
25-PC1400	12	1400	820	1150	850	65	55	125	9.46 (240.3)	6.84 (173.7)	8.69 (220.7)	50.0 (22.7)	SAE	70 (7.9)	2.5	3100A
35-PC1400	12	1400	820	1150	850	65	55	125	9.46 (240.3)	6.84 (173.7)	8.69 (220.7)	50.0 (22.7)	SAE	70 (7.9)	2.5	3100A
34-PC1500	12	1500	880	1250	1050	68	62	135	10.85 (275.6)	6.76 (171.7)	7.82 (198.6)	49.5 (22.4)	SAE	60 (6.8)	2.5	3100A
34R-PC1500	12	1500	880	1250	1050	68	62	135	10.85 (275.6)	6.76 (171.7)	7.82 (198.6)	49.5 (22.4)	SAE	60 (6.8)	2.5	3100A
34M-PC1500	12	1500	880	1250	1050	68	62	135	10.85 (275.6)	6.76 (171.7)	7.82 (198.6)	49.5 (22.4)	SAE and 3/8" Stud (Pos.), 5/16" Stud (Neg.)	70 (7.9)	2.5	3100A
34/78-PC1500	12	1500	880	1250	1050	68	62	135	10.85 (275.6)	6.99 (177.5)	7.82 (198.6)	49.5 (22.4)	TOP SAE SIDE 3/8" Receptacle	60 (6.8)	2.5	3100A
PC1700	12	1700	875	1325	1175	68	65	142	13.02 (330.7)	6.62 (168.2)	6.93 (176.0)	60.9 (27.6)	M6 Receptacle† or SAE 3/8" Receptacle	60 (6.8)	3.5	3500A
65-PC1750	12	1750	930	1350	1070	74	65	135	11.83 (300.5)	7.20 (182.9)	7.43 (188.7)	58.0 (26.3)	SAE	70 (7.9)	2.0	5000A
PC1800-FT	12	1800	1300	1600	1450	214	190	475	22.75 (577.9)	4.4 (125.0)	12.44 (316.0)	132.3 (60.0)	3/8" stud	80.0 (9.0)	3.3	3800A
31-PC2150	12	2150	1150	1545	1370	100	92	205	13.00 (330.2)	6.80 (172.7)	9.41 (239.0)	77.8 (35.3)	3/8" Stud or SAE†	150-220 (16.9-22.6)	2.2	5000A
31M-PC2150	12	2150	1150	1545	1370	100	92	205	13.00 (330.2)	6.80 (172.7)	9.47 (240.5)	77.8 (35.3)	SAE and 3/8" Stud (Pos.), 5/16" Stud (Neg.)	150-220 (16.9-22.6)	2.2	5000A
PC2250	12	2250	1225	1730	1550	126	114	240	11.26 (286.0)	10.59 (269.0)	9.17 (233.0)	86.0 (39.0)	Dual SAE/DIN Terminal and 3/8" Stud	100 (11.0) For 3/8" Stud Only	2.1	5000A

MAINTENANCE

ODYSSEY® batteries are very different from standard liquid-acid batteries that are openly vented. The ODYSSEY battery is and operates as a sealed battery, recycling all gases internally. There is no corrosion of the positive terminal or corrosion to the surrounding area. ODYSSEY batteries are shipped fully charged from the factory, but prior to installation, check the battery's voltage to see if it is 12.65 volts or greater. If not, recharge it using the procedure below.

Do not charge in an air tight compartment

Never attempt to remove the top decal cover, as it will cause the battery to fail.

CHARGING

The state of charge in an ODYSSEY battery can be determined from the following chart:

Voltmeter Reading	State of Charge
12.84 Volts or higher	100%
12.50 Volts	75%
12.18 Volts	50%
11.88 Volts	25%

To get long life from the ODYSSEY battery, it is important that the battery is kept near full charge, approximately 12.8 volts. If there are electrical loads during storage, then the negative battery cable should be disconnected or an independent float charger used. Low power 2.0 amp chargers for storage charge will keep a fully charged battery fully charged but cannot recharge if the ODYSSEY battery becomes discharged.

Racing Vehicles using total loss (no alternator) - standard automotive type chargers are not designed to return 105-108% of the energy removed. They normally boost charge to 80-95% and expect the alternator to complete the charge. Chargers listed on our website at www.odysseybattery.com are specifically designed for ODYSSEY batteries that are routinely deeply discharged. They provide the 105-108% recharge and then switch to storage charge.

ODYSSEY Ultimizer™ chargers as listed on www.odysseybattery.com are specifically designed for ODYSSEY batteries and are required for routine deep discharge applications. They provide 105-108% recharge and then switch to a storage charge.

To fully charge a 31-PC2150 battery that is routinely discharged deeply, a minimum of 40 amps are required with charger voltage within the range of 14.1V to 14.7V. It is imperative not to exceed 15.0V as this will cause the pressure valves to open and out-gas hydrogen, oxygen and water from inside the battery. This will shorten the life of the battery and cause premature failure. Some portable chargers exceed 15.0V, especially two-wheel garage chargers, so charging voltages should be verified by measuring the charging voltage during the time when the charging amperage is reducing from full output. The deep cycle charging voltage must be within 14.1V minimum to 14.7V maximum.

If a standard automotive charger is used to boost charge a discharged battery because of an accessory left on, it is important to make sure the charging voltage does not exceed 15 volts during charge. A hand held voltmeter can be used to monitor this periodically. The following chart provides recharge times under this type of boost charging to an 80-95% recharge and then allows the vehicle charging system to complete the charge.

24V BATTERY CONNECTION

To power a 24V trolling motor, you will need to connect two ODYSSEY® batteries in series. As shown in the top illustration, the negative of Battery 1 is wired to the positive of Battery 2. Hook up the positive terminal of Battery 1 to the positive terminal of your trolling motor and the negative terminal of Battery 2 to the negative terminal of the trolling motor.

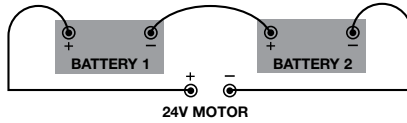

36V BATTERY CONNECTION

To power a 36V trolling motor, you will need to connect three ODYSSEY batteries in series. As shown in the bottom illustration, the negative of Battery 1 is wired to the positive of Battery 2; the negative of Battery 2 is then connected to the positive of Battery 3. Finally, hook up the positive terminal of Battery 1 to the positive terminal of your trolling motor and the negative terminal of Battery 3 to the negative terminal of the trolling motor.

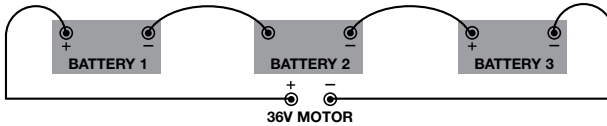

ODYSSEY® Battery Model	Charge time for 100% discharged battery (11.5 volts)	
	10-amp charger	20-amp charger
PC310	48 minutes	24 minutes
PC535	1 ½ hours	45 minutes
PC545	2 hours	1 hour
PC625	2 ¼ hours	1 ¼ hours
PC680	2 ½ hours	1 ¼ hours
PC925	3 ½ hours	1 ¾ hours
PC1200	4 hours	2 hours
75/86-PC1230	5 ½ hours	2 ¾ hours
25-PC1400 & 35-PC1400	6 hours	3 hours
34-PC1500, 34R-PC1500, 34M-PC1500 & 34/78-PC1500	7 hours	3 ½ hours
PC1700	7 hours	3 ½ hours
65-PC1750	7 ½ hours	3 ¾ hours
PC1800-FT	Not Recommended	17 hours
31-PC2150 & 31M-PC2150	10 hours	5 hours
PC2250	12 hours	6 hours

WINTER STORAGE

The ODYSSEY battery does not lose its charged energy during cold storage temperatures, so there is no need to trickle or float charge during winter months. To store off-season, measure the battery voltage to make sure it is fully charged, 12.84 volts or greater; recharge if necessary. Disconnect the negative battery cable to prevent any applied electrical load during storage. The ODYSSEY battery cannot freeze down to -40°C (-40°F), -30°C (-22°F) for PC2250, so it can be left in the vehicle. It can be stored for 2 years or more below 77°F.

A 12V, 3 amp trickle charger can also be left connected to the battery if it is kept in storage for extended periods or if the battery is subject to parasitic loads during storage. The trickle charge voltage measured at the battery terminals must be between 13.5V and 13.8V. We recommend using the ODYSSEY Ultimizer™ charger for your battery. For more information on these chargers, including where to buy them, can be found on our website at www.odysseybattery.com.

WARRANTY:

EnerSys Energy Products Inc. ("Manufacturer") warrants its ODYSSEY® batteries (hereafter referred to as "Battery") to be free of defects in material and workmanship for the earlier of (a) the Applicable Warranty Period or (b) within 400 cycles to 80% depth of discharge, whichever occurs first. The Applicable Warranty Period is two (2) years for power sports applications; three (3) years in automotive, marine, commercial, and industrial applications; and four (4) years in the case of the 75/86-PC1230, 25-PC1400, 35-PC1400, 34-PC1500, 34R-PC1500, 34M-PC1500, 34/78-PC1500, 65-PC1750, 31-PC2150, 31M-PC2150 and PC2250 batteries. The Applicable Warranty Period begins from the date of purchase with original receipt, or, if no receipt is available, from Manufacturer's shipping date. Within the Applicable Warranty Period, the Battery will be replaced free of charge if adjustment is necessary due to defect in material or workmanship (not merely discharged). Simply return the Battery to any authorized ODYSSEY battery dealer with the original receipt for a replacement. This warranty may vary from country to country; contact your authorized ODYSSEY battery wholesaler or dealer for the applicable warranty.

GENERAL PROVISIONS:

A. Manufacturer has no obligation under the limited warranty set forth above in the event the Battery is damaged or destroyed as a result of one or more of the following:

- Willful abuse or neglect or if the top decorative cover has been removed.
- Natural forces such as wind, lightning, hail; damage due to fire, collision, explosion, vandalism, theft, penetration or opening of the Battery case in any manner.
- Overcharging, undercharging, charging or installing in reverse polarity, improper maintenance, allowing the Battery to be deeply discharged via a parasitic load or mishandling of the Battery such as but not limited to using the terminals for lifting or carrying the Battery. Trickle chargers that do not have a regulated trickle charge voltage between 13.5V and 13.8V (no lower than 13.5V and no higher than 13.8V) will cause early failure of the Battery. Use of such chargers with the Battery will also void the Battery's warranty.
- Failure to properly install the Battery or lack of metal jacket for high temperature or vibration applications.
- Normal deterioration in the electrical qualities or the acceleration of such deterioration due to conditions that accelerate such deterioration.
- If the Battery is used for an application that requires higher cranking power or a greater reserve rating than the Battery is designed to deliver, or the Battery capacity is less than the Battery capacity specified by the vehicle manufacturer, or the Battery is otherwise used in applications for which it was not designed.
- **WARNING - Do NOT** use any type of oil, organic solvent, alcohol, detergent, strong acids, strong alkalis, petroleum-based solvent or ammonia solution to clean the jars or covers. These materials may cause permanent damage to the battery jar and cover and will void the warranty.

B. To obtain warranty service:

1. Return the Battery to any authorized ODYSSEY battery wholesaler or dealer.
2. If the Battery is determined to be defective for material or workmanship under terms of this limited warranty, it will be replaced.
3. Manufacturer's acceptance of any items shipped to Manufacturer shall not be deemed an admission that the items so shipped are defective. Any items shipped back to Manufacturer, shall in Manufacturer's sole discretion, become Manufacturer's sole property.

THIS LIMITED WARRANTY IS IN LIEU OF, AND MANUFACTURER DISCLAIMS AND EXCLUDES ALL OTHER WARRANTIES, STATUTORY, EXPRESS OR IMPLIED, INCLUDING, WITHOUT LIMITATION, ANY WARRANTY OF MERCHANTABILITY OR FITNESS FOR A PARTICULAR PURPOSE. MANUFACTURER'S EXCLUSIVE LIABILITY FOR BREACH OF WARRANTY SHALL BE TO REPLACE THE BATTERY WITHIN THE EFFECTIVE WARRANTY PERIOD. IN NO EVENT SHALL MANUFACTURER BE LIABLE FOR ANY LOSS OR DAMAGES OF ANY OTHER KIND, WHETHER DIRECT, INCIDENTAL, CONSEQUENTIAL, EXEMPLARY, SPECIAL OR OTHERWISE. NOR SHALL MANUFACTURER BE LIABLE FOR ANY REMOVAL OR INSTALLATION EXPENSE, OR THE LOSS OF TIME OR PROFITS. Some countries and/or states do not allow limitation on how long an implied warranty lasts or the exclusion or limitation of incidental or consequential damages, so the above limitations may not apply to you. This warranty gives you specific legal rights, which may vary from country to country and/or state to state.

Keep your receipt. Receipt is required for longest Warranty Protection.

For your convenience, this space is provided for attaching your original receipt.

Always properly recycle your lead acid battery by returning to an authorized recycling center or automotive dealer.



NEVER PLACE USED BATTERIES IN THE BIN!

EnerSys

P.O. Box 14145
Reading, PA 19612-4145, USA
Tel: +1-610-208-1991
+1-800-538-3627
Fax: +1-610-372-8613

Regional Sales

EnerSys Energy Products Inc.
617 North Ridgeview Drive
Warrensburg, MO 64093-9301, USA
Tel: +1-660-429-2165
Fax: +1-660-429-1758

EnerSys Australia Pty Ltd.
54-58 Derby Street
Silverwater, NSW 2128
Australia
Tel: + 61 (0) 2 9739 9999
Fax: + 61 (0) 2 9739 9900

Website: www.odysseybattery.com

© 2009 EnerSys. All rights reserved.

Trademarks and logos are the property of EnerSys and its affiliates, except General Motors®, which is not the property of EnerSys.